



(51) International Patent Classification:

G01F 15/00 (2006.01) G01R 11/00 (2006.01)
G01D 4/00 (2006.01)

(21) International Application Number:

PCT/EP2016/058934

(22) International Filing Date:

21 April 2016 (21.04.2016)

(25) Filing Language:

English

(26) Publication Language:

English

(71) Applicants: **CONSEJO SUPERIOR DE INVESTIGACIONES CIENTIFICAS (CSIC)** [ES/ES]; C/ Serrano, 117, 28006 Madrid (ES). **UNIVERSITAT AUTÒNOMA DE BARCELONA (UAB)** [ES/ES]; Edifici A. Campus Universitari s/n, 08193 Bellaterra (Cerdanyola del Valles) (ES). **KROMSCHROEDER, S.A.** [ES/ES]; C/ Santa Eulalia, 213, 08902 L'Hospitalet (Barcelona) (ES).

(72) Inventors: **FORTUNA PÉREZ, Hilario**; Kromschroeder, S.A., C/ Santa Eulalia, 213, 08902 L'Hospitalet (Barcelona) (ES). **VALERO URREA, José**; Kromschroeder, S.A., C/ Santa Eulalia, 213, 08902 L'Hospitalet (Barcelona) (ES).

GRANADOS GARCÍA, Javier Alberto José; Instituto de Ciencia de Materiales Barcelona, Campus de la UAB, 08193 Bellaterra (Cerdanyola del Valles) (ES). **RI-CART MIRÓ, Susana**; Instituto de Ciencia de Materiales Barcelona, Campus de la UAB, 08193 Bellaterra (Cerdanyola del Valles) (ES). **PALMER PARICIO, Javier**; Universitat Autònoma de Barcelona (UAB), Edifici Q. Campus Universitari s/n, 08193 Bellaterra (Cerdanyola del Valles) (ES). **ALCALDE ARAGONÉS, Ana**; Universitat Autònoma de Barcelona (UAB), Edifici Q. Campus Universitari s/n, 08193 Bellaterra (Cerdanyola del Valles) (ES). **CARRABINA BORDOLL, Jordi**; Universitat Autònoma de Barcelona (UAB), Edifici Q. Campus Universitari s/n, 08193 Bellaterra (Cerdanyola del Valles) (ES).

(74) Agent: **PONS ARIÑO, Ángel**; Glorieta de Rubén Darío, 4, 28010 Madrid (ES).

(81) Designated States (unless otherwise indicated, for every kind of national protection available): AE, AG, AL, AM, AO, AT, AU, AZ, BA, BB, BG, BH, BN, BR, BW, BY, BZ, CA, CH, CL, CN, CO, CR, CU, CZ, DE, DK, DM, DO, DZ, EC, EE, EG, ES, FI, GB, GD, GE, GH, GM, GT, HN, HR, HU, ID, IL, IN, IR, IS, JP, KE, KG, KN, KP, KR, KZ, LA,

(54) Title: DEVICE FOR DETECTING FRAUD IN METERS AND RELATED METHOD

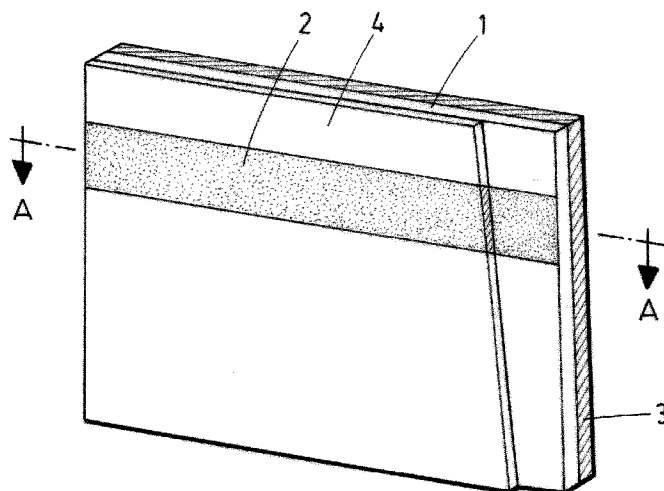

FIG.1

(57) Abstract: The present invention relates to a device and a method for detecting fraud in energy, fluid or other meters that provide a cheap qualitative tool to detect the fraud in the meters that takes place by enclosing a strong magnet on the gauge of the meter. When this external magnetic field is applied on the device situated near the gauge, the magnetization of a previously encoded magnetic stripe is destroyed.



LC, LK, LR, LS, LU, LY, MA, MD, ME, MG, MK, MN, MW, MX, MY, MZ, NA, NG, NI, NO, NZ, OM, PA, PE, PG, PH, PL, PT, QA, RO, RS, RU, RW, SA, SC, SD, SE, SG, SK, SL, SM, ST, SV, SY, TH, TJ, TM, TN, TR, TT, TZ, UA, UG, US, UZ, VC, VN, ZA, ZM, ZW.

(84) Designated States (*unless otherwise indicated, for every kind of regional protection available*): ARIPO (BW, GH, GM, KE, LR, LS, MW, MZ, NA, RW, SD, SL, ST, SZ, TZ, UG, ZM, ZW), Eurasian (AM, AZ, BY, KG, KZ, RU, TJ, TM), European (AL, AT, BE, BG, CH, CY, CZ, DE, DK, EE, ES, FI, FR, GB, GR, HR, HU, IE, IS, IT, LT, LU, LV, MC, MK, MT, NL, NO, PL, PT, RO, RS, SE, SI, SK, SM, TR), OAPI (BF, BJ, CF, CG, CI, CM, GA, GN, GQ, GW, KM, ML, MR, NE, SN, TD, TG).

Published:

— *with international search report (Art. 21(3))*

DEVICE FOR DETECTING FRAUD IN METERS AND RELATED METHOD**DESCRIPTION****5 OBJECT OF THE INVENTION**

The present invention relates to a device for detecting fraud in meters, the kind of fraud that takes place by the use of an external magnet attached over the meter's gauge. This invention relates to gauge meters which possess mobile
10 parts whose motion can be stopped by the application of a magnetic field. The invention is especially relevant for fluid or energy meters, but it is not restricted to these kinds of meters. The invention can generally be applied to any meter possessing mobile parts whose motion can be stopped by the application of a magnetic field.

15

A first object of the invention is a device for detecting fraud in meters (i.e. fluid or energy meters) in the form of a magnetic strip with an encoded pattern.

A second object of the invention is a method for detecting fraud in meters that
20 allows meter readers check possible manipulation over the meter.

BACKGROUND OF THE INVENTION

A frequent fraud that fluid or energy meter readers find when checking a fluid or
25 energy meter, particularly gas, water and electricity meters, is that the measure can be disrupted due to the application of a strong magnet, with a magnetic flux density sufficient to stop the motion of mobile parts and consequently stopping the metering function of the meter, freezing the current value measured even if water, gas or energy is being consumed. For the sake of information and not
30 the sake of limitation of the invention, it is known that a magnetic flux density higher than approximately 0.2 Tesla, when applied over the gauge is sufficient to stop meters available in the market and installed in residences. This kind of

manipulation doesn't leave any mark and the human meter readers don't have an accurate idea of the time it has been manipulated or if it has been really manipulated, so they can only rely in estimations of the gas consumption.

- 5 Most of the solutions found to avoid that problem are based in mechanical approaches. Some documents related to this kind of detection are US6666083B2 and EP1564533B1.

10 US6098456 discloses an anti-fraud liquid meters having a drive and driven magnets with double polarity faces, that establishes a magnetic equilibrium with an external magnet which blocks the meter. This is a viable solution for new installations, which are no longer vulnerable to the effect of external magnets, but there's still a big settled base of old models, which turns too expensive to do a total substitution for new ones, or even an intrusive modification of the actual
15 meters. These systems use magnets inside the meter to overcome the effect of a magnetic intrusion.

EP1921426A1 discloses a tamper-proof counter for a flow meter that has a counting device operated by a measuring device, which is displaceable by a
20 flow medium e.g. gas, in flow. A sensor e.g. reflection photo sensor, is provided for detecting external force impact on the counting device, where deflection of a protective housing is automatically detectable by the sensor. However, this counting device is efficient only if an impact has been directed to the counting device.

25

The device and method for detecting fraud in fluid or energy or general application meters of the present invention solve the above cited drawbacks providing a non-intrusive device and method to check possible fraud in meters and any other devices that can be manipulated with the use of external
30 magnets.

DESCRIPTION OF THE INVENTION

The present invention relates to a device for detecting fraud in meters that provides a cheap and non-intrusive qualitative tool to detect this fraud that takes place by enclosing a strong magnet on a gauge of the meter, causing a stop in the mobile parts of the measurement device and consequently a stop in the count of the service or goods being provided. Goods being provided may include fluids like water and gas measured by meters. Services being provided may include electricity measured by energy meters. This invention relates to gauge meters which possess mobile parts whose motion can be stopped by the application of a magnetic field. The invention is especially relevant for fluid or energy meters, but it is not restricted to these kinds of meters. The invention can generally be applied to any meter possessing mobile parts whose motion can be stopped by the application of a magnetic field, so that then measurement is stopped.

The device for detecting fraud in meters comprises at least one magnetic strip and means to couple the at least one magnetic strip to the meter. The magnetic strip can have any format, including circular, triangular, rectangular elliptical and other possible formats. The means to couple the magnetic strip to the meter include gluing, screwing, riveting or other forms of coupling or attaching the magnetic strip. The means to couple the at least one magnetic strip to the meter could also comprise a label coupled to the meter in such a way that the magnetic strip is applied on a label that is then attached to the body or the gauge of the meter. This label can be done in any format or shape and the label has the function to act as part of the means to couple the magnetic strip to the meter. The working principle of the invention is that the magnetic strip has its intrinsic pattern altered by the application of a magnetic field. As the fraud is perpetrated by applying magnetic fields using magnets, this is detected as a visible modification with respect to the original pattern in the magnetic field.

The at least one magnetic strip is coded with a magnetic pattern, wherein the

magnetic pattern of the at least one magnetic strip is destroyable by the application of an external magnetic field on the label.

5 Optionally, the device also comprises a magnetic viewing film being capable of reacting to the external magnetic field applied on the label and being capable of displaying the magnetic pattern of the at least one magnetic strip. This magnetic viewing film provides a device for detecting fraud in meters that discerns if the magnetic pattern coded in the at least one magnetic strip has been destroyed by the use of an external magnetic field applied on the label.

10

The size of the label of the device can be optimized for each type of meter that can be affected by an external magnetic field.

15 The less the distance of the label to the gauge is, the same magnetic field is applied on the label than the magnetic field applied on the gauge.

The present invention also relates to a method for detecting fraud in meters comprising the following stages:

- 20 • a stage of attaching at least one magnetic strip coded with a magnetic pattern to the meter,
- a stage of inspecting the magnetic strip to verify if the magnetic pattern has been changed.

25 Optionally, the stage of attaching the at least one magnetic strip coded with the magnetic pattern to the meter comprises attaching the at least one magnetic strip to a label before attaching of the label and the at least one magnetic strip to the meter.

30 Optionally, the method also comprises a stage of coding the at least one magnetic strip with the magnetic pattern previous to the stage of attaching the at least one magnetic strip coded with the magnetic pattern to the label or to the meter.

Optionally, the method also comprises a stage of checking a magnetic viewing film, wherein the magnetic viewing film is capable of reacting to the external magnetic field applied on the at least one magnetic strip and being capable of displaying the magnetic pattern of the at least one magnetic strip, thus discerning if the magnetic pattern coded in the at least one magnetic strip has been at least partially damaged or destroyed by the use of the external magnetic field applied on the at least one magnetic strip.

10 The result of the method of detecting fraud is positive, indicating that fraud was attempted, if the magnetic pattern has changed. If the magnetic pattern remains unchanged, the result of the method to detect fraud is negative, indicating that no magnetic field was applied to perform fraud.

15 **BRIEF DESCRIPTION OF THE DRAWINGS**

Figure 1 shows a perspective view of the device for detecting fraud in meters of the present invention according to the third preferred embodiment.

20 Figure 2 shows a section view AA of the Figure 1.

Figure 3 shows a perspective view of a meter, emphasizing the position of the device shown in Figure 1 or Figure 2.

25 Figures 4 and 5 show two different schematic views of a stage of checking a magnetic viewing film of the method for detecting fraud in meters of the present invention, using an external magnetic viewing film tool.

PREFERRED EMBODIMENT OF THE INVENTION

30

In a preferred embodiment of the invention, the device for detecting fraud in meters comprises a label (1) preferably comprised of substrate paper being

coupled to a gauge (7) which does the count of the consumption of the meter (6).

5 The device further comprises a magnetic strip (2) previously coded with a magnetic pattern, wherein the magnetic strip (2) is preferably stuck to or compressed over the label (1) and wherein the magnetic pattern of the magnetic strip (2) is destroyable by the application of an external magnetic field on the label (1).

10 The magnetic strip (2) presents a moderate to high coercivity according to the current magnetic band standards, i.e. higher than around 2700 Oersted, to ensure the stability of the coded magnetic pattern and according to the magnetic sensitivity of the gauge (7). At the same time the magnetic strip (2) is weak enough to be destroyed with the proximity of an external magnetic field,
15 used to perpetrate the fraud. It is known that usually a magnetic flux density higher than approximately 0.2T that blocks the metering operation by disrupting the proper measure of the gauge (7), this value is provided as an information of the current practice used to commit frauds, and not as a limitation of the invention.

20

The device further comprises fixing means (3) for permanently joining the label (1), and in consequence the magnetic strip (2), to the meter (3). Preferably, the fixing means (2) are a glued film. This glued film is heavily attached to the meter (6), so not even corners are easily detached. In case the label (1) is scratched,
25 the glued film leaves some rests in the surface of the meter (6) to advise the inspectors or human readers that an aggressive action has took place.

The device further comprises a protective layer (4) disposed over the label (1) which covers entirely the device and protects it from atmospheric conditions
30 (humidity, UV radiation, etc).

The device further comprises a magnetic viewing film (5) being capable of

reacting to the external magnetic field applied on the label (1) and being capable of displaying the magnetic pattern of the magnetic strip (2) for discerning if the magnetic pattern coded in the magnetic strip (2) has been destroyed by the use of an external magnetic field applied on the label (1).

5

Preferably, the magnetic viewing film (5) comprises particles contained inside it suspended in a fluid carrier, which allows said particles to respond to the external magnetic field and be orientated over it, so the magnetic pattern is visually displayed. Most preferably, the magnetic viewing film (5) is
10 encapsulated between two transparent layers (not shown).

In a first preferred embodiment, the magnetic viewing film (5) is a microencapsulated flexible viewing film comprising two thin transparent layers with magnetic micro-particles (mainly nickel or a nickel alloy) captured in
15 between. The particles have enough space to move and reposition when a magnetic field is applied. These films can be easily manipulated. The magnetic viewing film (5) so constituted comprises a transparent capsule (not shown) to protect it (5).

20 In a second preferred embodiment, the magnetic viewing film (5) is a magnetorheological fluid (MRF). The production of this MRF consists essentially in a dispersion of magnetic micro-particles (preferably of iron, nickel or cobalt, and their alloys with a size smaller than 10 μm) on a fluid carrier (preferably a silicone oil or a mineral oil), optionally mixed with some additive in order to
25 stabilize these particles and prevent precipitation. The magnetorheological fluid is then encapsulated between two transparent layers of preferably a tough material, as can be polyurethane, polystyrene, PET, PEN, etc. The magnetic viewing film (5) so constituted comprises a non-dark coloured capsule in such a manner that the particles of the viewing film (5) can be easily viewed with higher
30 contrast.

This magnetic viewing film (5) is especially necessary in cases when the

magnetic strip (2) is usually dark coloured, black or dark-brown (though it can be encapsulated using layers with other colours), and the magnetic pattern coded in the magnetic strip (2) is invisible to the human eye.

- 5 In a third preferred embodiment, the magnetic viewing film (5) is attached to the label (1) in such a way that the magnetic pattern is permanently displayed on the meter, being visible to the customer, such that this magnetic viewing film (5) can discourage him from manipulating the meter (6).
- 10 In a fourth preferred embodiment, the magnetic viewing film (5) is separately disposed from the label (1), preferably being placed in a tool (10) for detecting the destruction of the magnetic pattern of the magnetic strip (2) by the application of the external magnetic field on the label (1). So, the customer ignores the presence of the magnetic pattern.

15

As shown in Figures 4 and 5, a visible pattern (11) of the label (1) is displayed by the tool (10) comprising the magnetic viewing film (5) due to the properly reorganization of the micro-particles inside the fluid with the magnetic field of the stripe. If the meter (6) is manipulated with the use of a magnetic field, the organized magnetic domains of the magnetic strip (2) are destroyed and no visible pattern would be displayed, so the particles will remain randomly oriented or aggregated according to the effect of the magnetic field of the external magnet over them.

- 25 The method for detecting fraud in fluid meters comprises the following stages:
- a stage of attaching at least one magnetic strip (2) previously coded with a magnetic pattern to the meter (6),
 - a stage of inspecting the magnetic strip (2) to verify if the magnetic pattern has been changed.

30

Preferably, the stage of attaching the at least one magnetic strip (2) coded with the a magnetic pattern to the meter (6) comprises attaching the at least one

magnetic strip (2) to a label (1) before attaching the label (1) and the at least one magnetic strip (2) to the meter (6), preferably to a gauge (7) of the meter (6).

5 The method for detecting fraud in meters further comprises:

- a stage of checking a magnetic viewing film (5), wherein the magnetic viewing film (5) is capable of reacting to the external magnetic field applied on the label (1) and being capable of displaying the magnetic pattern of the magnetic strip (2), discerning if the magnetic pattern coded
10 in the magnetic strip (2) has been destroyed by the use of the external magnetic field applied on the label (1).

Optionally, the method also comprises a stage of coding the at least one magnetic strip (2) with the magnetic pattern previous to the stage of attaching
15 the at least one magnetic strip (2) previously coded with the magnetic pattern to the label (1) or directly to the meter (6).

Optionally, the method also comprises a stage of checking a magnetic viewing film, wherein the magnetic viewing film is capable of reacting to the external
20 magnetic field applied on the label and being capable of displaying the magnetic pattern of the at least one magnetic strip, thus discerning if the magnetic pattern coded in the at least one magnetic strip has been at least partially damaged or destroyed by the use of the external magnetic field applied on the label.

25 Preferably this stage of checking a magnetic viewing film (5) can be made by means of an external tool or can be shown in the meter (6).

CLAIMS

1. Device for detecting fraud in meters, the fraud that takes place by applying an external magnetic field on the meter (6) characterised in that the device comprises:
- 5
- at least one magnetic strip (2), and
 - means (1) to couple the at least one magnetic strip to the meter (6).
2. Device for detecting fraud in meters, according to claim 1, characterised in that the at least one magnetic strip (2) is coded with a magnetic pattern, wherein the magnetic pattern of the at least one magnetic strip (2) is destroyable by the application of the external magnetic field.
- 10
3. Device for detecting fraud in meters, according to any of previous claims, characterised in that the means to couple the at least one magnetic strip to the meter (6) comprise a label (1) coupled to the meter (6).
- 15
4. Device for detecting fraud in meters according to claim 3 characterised in that it also comprises fixing means (3) for permanently joining the label (1), and in consequence the at least one magnetic strip (2) to the meter (3).
- 20
5. Device for detecting fraud in meters according to claim 4 characterised in that the fixing means (3) are a glued film.
6. Device for detecting fraud in meters according to any of previous claims 3 to 5 characterised in that it also comprises a protective layer (4) disposed over the label (1) which covers entirely the device.
- 25
7. Device for detecting fraud in meters according to claim 6 characterised in that it also comprises a magnetic viewing film (5) being capable of reacting to the external magnetic field applied on the label (1) and being capable of displaying the magnetic pattern of the at least one magnetic strip (2).
- 30

8. Device for detecting fraud in meters according to claim 7 characterised in that the magnetic viewing film (5) comprises particles contained inside it suspended in a fluid carrier, which allows said particles to respond to the external magnetic field and be orientated over it, so the magnetic pattern is visually displayed.
- 5
9. Device for detecting fraud in meters according to claim 8 characterised in that the magnetic viewing film (5) is encapsulated between two transparent layers.
- 10
10. Device for detecting fraud in meters according to claim 9 characterised in that the magnetic viewing film (5) is a microencapsulated flexible viewing film comprising two thin transparent layers with magnetic micro-particles captured in between and a transparent capsule to protect it (5).
- 15
11. Device for detecting fraud in meters according to claim 9 characterised in that the magnetic viewing film (5) is a magnetorheological fluid (MRF) consisting in a dispersion of magnetic micro-particles on a fluid carrier.
- 20
12. Device for detecting fraud in meters according to claim 7 characterised in that the magnetic viewing film (5) is attached to the label (1) in such a way that the magnetic pattern is permanently displayed on the meter.
- 25
13. Device for detecting fraud in meters according to claim 7 characterised in that the magnetic viewing film (5) is separately disposed from the label (1).
- 30
14. Device for detecting fraud in meters according to claim 13 characterised in that the magnetic viewing film (5) is placed in a tool (10) for detecting the destruction of the magnetic pattern of the at least one magnetic strip (2) by the application of the external magnetic field on the label (1).

15. Device for detecting fraud in meters according to claim 14 characterised in that the tool (10) displays a visible pattern (11) of the label (1).

16. Device for detecting fraud in meters according to any of the previous
5 claims characterised in that the at least one magnetic strip (2) presents a coercivity higher than around 2700 Oersted with a magnetic flux density higher than 0.2T.

17. Meter comprising the device according to any of the previous claims.
10

18. Method for detecting fraud in meters characterised in that it comprises the following stages:

- a stage of attaching at least one magnetic strip (2) coded with a magnetic pattern to the meter (6),
- 15 • a stage of inspecting the magnetic strip (2) to verify if the magnetic pattern has been changed.

19. Method for detecting fraud in meters, according to claim 18, characterised in that:

- 20 • the stage of attaching the at least one magnetic strip (2) coded with the a magnetic pattern to the meter (6) comprises attaching the at least one magnetic strip (2) to a label (1) before attaching the label (1) and the at least one magnetic strip (2) to the meter (6).

20. Method for detecting fraud in meters according to any of claims 18 or 19 characterised in that it also comprises:

- a stage of coding at least one magnetic strip (2) with a magnetic pattern previous to the stage of attaching the at least one magnetic strip (2) coded with the magnetic pattern to the meter (6) or to the label (1).

30

21. Method for detecting fraud in meters according to any of claims 18 to 20 characterised in that it also comprises:

- a stage of checking a magnetic viewing film (5), wherein the magnetic viewing film (5) is capable of reacting to the external magnetic field applied on the at least one magnetic strip (2) and being capable of displaying the magnetic pattern of the at least one magnetic strip (2),
5 discerning if the magnetic pattern coded in the at least one magnetic strip (2) has been at least partially damaged or destroyed by the use of the external magnetic field applied on the at least one magnetic strip (2).

22. Method for detecting fraud in meters according to claim 21 characterised
10 in that the stage of checking the magnetic viewing film (5) is carried out by means of an external tool.

23. Method for detecting fraud in meters according to claim 21 characterised
15 in that the stage of checking the magnetic viewing film (5) is shown in the meter (6).

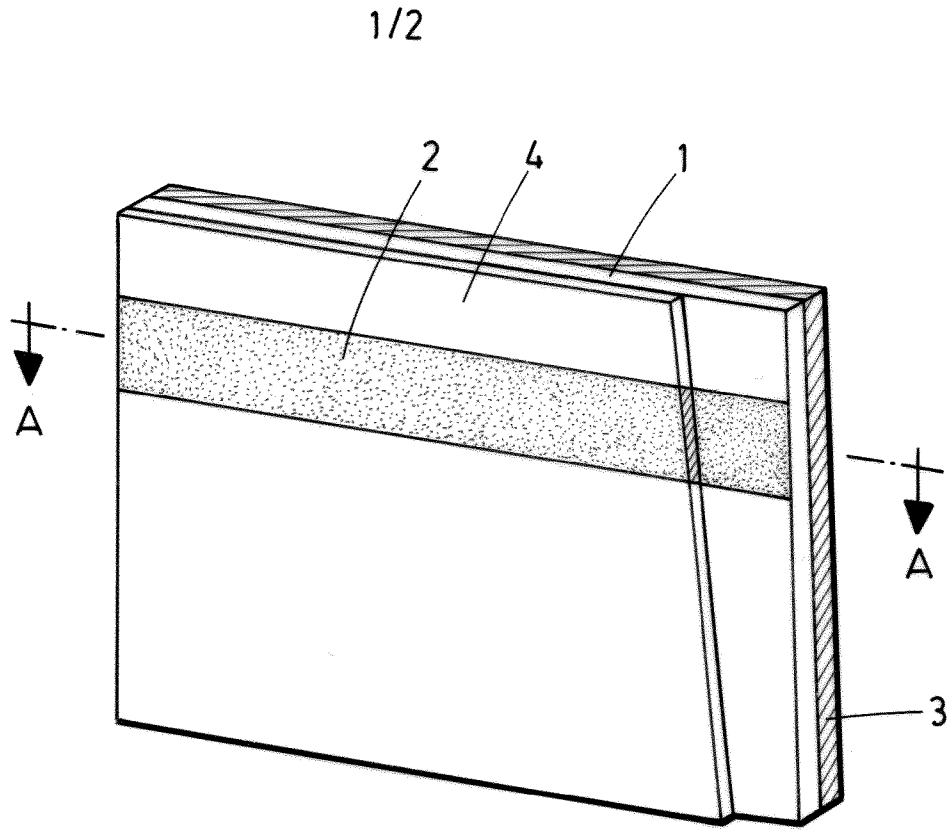

FIG.1

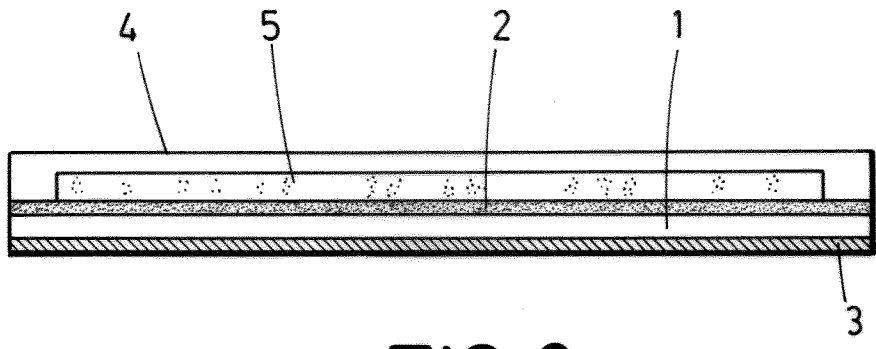

FIG.2

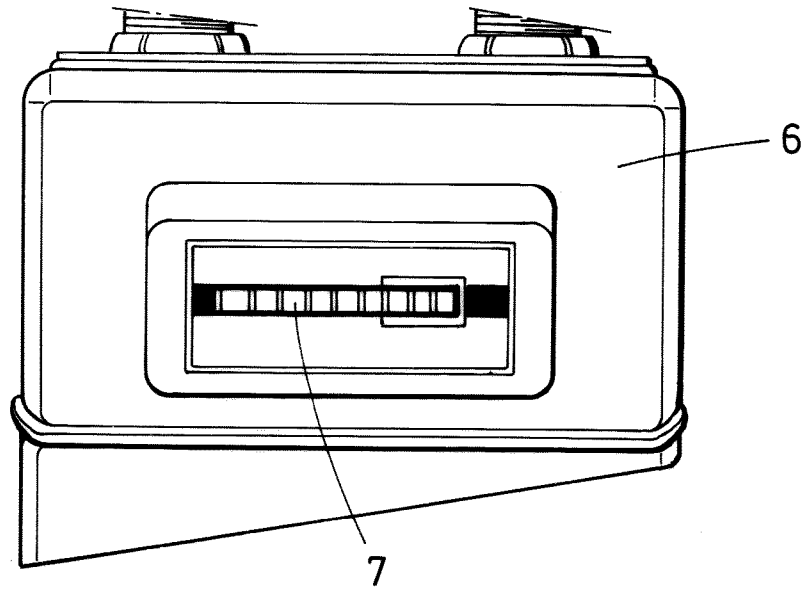

FIG. 3

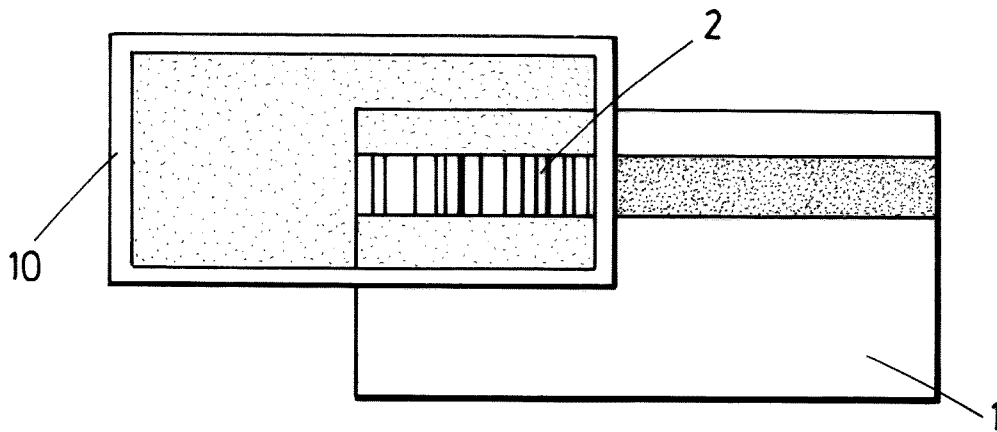

FIG. 4

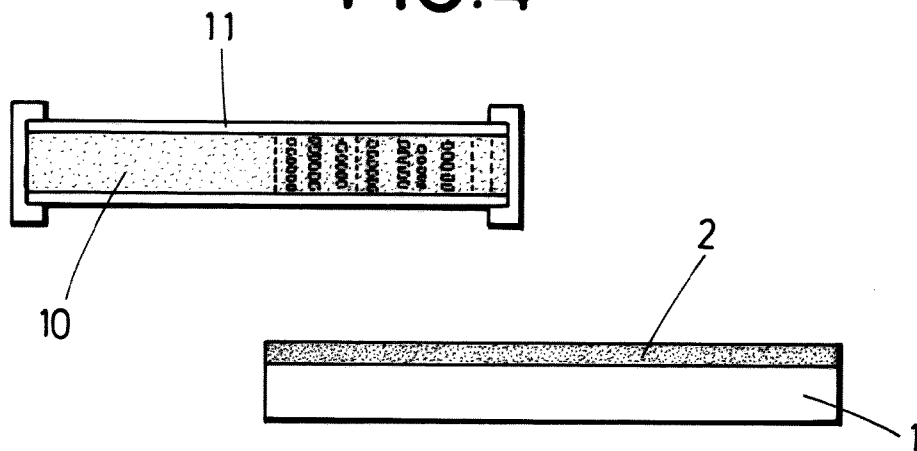

FIG. 5

INTERNATIONAL SEARCH REPORT

International application No
PCT/EP2016/058934

A. CLASSIFICATION OF SUBJECT MATTER
 INV. G01F15/00 G01D4/00 G01R11/00
 ADD.

According to International Patent Classification (IPC) or to both national classification and IPC

B. FIELDS SEARCHED

Minimum documentation searched (classification system followed by classification symbols)
 G01F G01D G01R

Documentation searched other than minimum documentation to the extent that such documents are included in the fields searched

Electronic data base consulted during the international search (name of data base and, where practicable, search terms used)
 EPO-Internal, WPI Data

C. DOCUMENTS CONSIDERED TO BE RELEVANT

Category*	Citation of document, with indication, where appropriate, of the relevant passages	Relevant to claim No.
X	WO 03/065055 A2 (ISKRAEMECO MERJENJE IN UPRAVLJ [SI]; BURGAR JANKO [SI]; JENSTERLE MATK) 7 August 2003 (2003-08-07)	1-7,12, 16-21,23
Y	page 4, paragraphs 2,3; figures 1,2a,2b,8 page 6, last paragraph - page 7, paragraph 2; claims 8,9	8-11, 13-15,22
Y	----- GB 2 178 481 A (PLESSEY CO PLC) 11 February 1987 (1987-02-11) page 1, lines 48-65 - page 2, line 62; claims 3,4; figures 1,2	8-11, 13-15,22
A	----- US 2008/210757 A1 (BURDEN ADRIAN PAUL [SG] ET AL) 4 September 2008 (2008-09-04) paragraphs [0195], [0201] - [0203], [0242], [0314]; figures 4a-4h	1-23

Further documents are listed in the continuation of Box C. See patent family annex.

* Special categories of cited documents :

<p>"A" document defining the general state of the art which is not considered to be of particular relevance</p> <p>"E" earlier application or patent but published on or after the international filing date</p> <p>"L" document which may throw doubts on priority claim(s) or which is cited to establish the publication date of another citation or other special reason (as specified)</p> <p>"O" document referring to an oral disclosure, use, exhibition or other means</p> <p>"P" document published prior to the international filing date but later than the priority date claimed</p>	<p>"T" later document published after the international filing date or priority date and not in conflict with the application but cited to understand the principle or theory underlying the invention</p> <p>"X" document of particular relevance; the claimed invention cannot be considered novel or cannot be considered to involve an inventive step when the document is taken alone</p> <p>"Y" document of particular relevance; the claimed invention cannot be considered to involve an inventive step when the document is combined with one or more other such documents, such combination being obvious to a person skilled in the art</p> <p>"&" document member of the same patent family</p>
---	---

Date of the actual completion of the international search 18 January 2017	Date of mailing of the international search report 30/01/2017
--	--

Name and mailing address of the ISA/ European Patent Office, P.B. 5818 Patentlaan 2 NL - 2280 HV Rijswijk Tel. (+31-70) 340-2040, Fax: (+31-70) 340-3016	Authorized officer Rambaud, Dilek
--	--

INTERNATIONAL SEARCH REPORT

Information on patent family members

International application No

PCT/EP2016/058934

Patent document cited in search report	Publication date	Patent family member(s)	Publication date
WO 03065055	A2	07-08-2003	AU 2003238703 A1
			SI 21151 A
			WO 03065055 A2

GB 2178481	A	11-02-1987	NONE

US 2008210757	A1	04-09-2008	CN 101142598 A
			EP 1851732 A1
			JP 4685112 B2
			JP 2008527578 A
			MY 142337 A
			US 2008210757 A1
			WO 2006078220 A1
